

Incremental encoders

Standard stainless steel, optical	Sendix 5006 / 5026 (shaft / hollow shaft)	Push-pull / RS422
--	--	--------------------------



The incremental Sendix encoders 5006 / 5026 in stainless steel offers optimum material resistance and thus virtually unlimited durability.

The high-grade seals, the IP66/IP67 level of protection as well as the wide temperature range additionally ensure impermeability and ruggedness.



Safety-Lock™	High rotational speed	Temperature range -40...+85°C	High protection level IP	High shaft load capacity	Shock / vibration resistant	Magnetic field proof	Short-circuit proof	Reverse polarity protection	Optical sensor

Durable and sealed

- Protection rating IP66/IP67.
- Rugged stainless steel housing.
- Wide temperature range -40 °C ... +85 °C.
- Sturdy bearing construction in Safety Lock™ Design for resistance against vibration and installation errors.

Flexible in use

- Compatible with all common US and european standards.
- Supply voltage 5 ... 30 V DC, various interface options, max. 5000 pulses per revolution.
- Compact dimensions: outer diameter 50 mm, installation depth max. 47 mm.

Order code	8.5006	.XXXX4.	XXXX
Shaft version	Type	a b c d	e

- | | | |
|---|---|--|
| <p>a Flange</p> <p>7 = clamping flange \varnothing 58 mm [2.28"]</p> <p>A = synchro flange \varnothing 58 mm [2.28"]</p> <p>C = square flange \square 63.5 mm [2.5"]</p> <p>b Shaft ($\varnothing \times L$), with flat</p> <p>1 = \varnothing 6 x 10 mm [0.24 x 0.39"]</p> <p>3 = \varnothing 10 x 20 mm [0.39 x 0.79"]</p> <p>8 = \varnothing 3/8" x 7/8"</p> | <p>c Output circuit / supply voltage</p> <p>2 = push-pull (7272 compatible with inverted signal) / 5 ... 30 V DC</p> <p>5 = push-pull (with inverted signal) / 10 ... 30 V DC</p> <p>4 = RS422 (with inverted signal) / 5 V DC</p> <p>d Type of connection</p> <p>4 = radial M12 connector, 8-pin</p> <p>e Pulse rate</p> <p>1, 5, 10, 12, 36, 100, 200, 250, 256, 360, 400, 500, 512, 600, 800, 1000, 1024, 1200, 2000, 2048, 2500, 3600, 4096, 5000 (e.g. 100 pulses => 0100)</p> | <p><i>Optional on request</i></p> <ul style="list-style-type: none"> - other pulse rates - Ex 2/22 - seawater resistant (stainless steel V4A) <p><i>Stainless steel V4A as standard types (deliverable as from 1 unit)</i></p> <p>V4A 8.5006.73X4.XXXX-V4A</p> <p>1.4404</p> |
|---|---|--|

Order code	8.5026	.XXXX2.	XXXX
Hollow shaft	Type	a b c d	e

- | | | |
|---|--|--|
| <p>a Flange</p> <p>1 = with spring element, long</p> <p>C = with stator coupling, \varnothing 63 mm</p> <p>b Through hollow shaft</p> <p>2 = \varnothing 1/4"</p> <p>4 = \varnothing 3/8"</p> <p>3 = \varnothing 10 mm [0.39"]</p> <p>5 = \varnothing 12 mm [0.47"]</p> <p>6 = \varnothing 1/2"</p> <p>8 = \varnothing 15 mm [0.59"]</p> | <p>c Output circuit / supply voltage</p> <p>2 = push-pull (7272 compatible, with inverted signal) / 5 ... 30 V DC</p> <p>5 = push-pull (with inverted signal) / 10 ... 30 V DC</p> <p>4 = RS422 (with inverted signal) / 5 V DC</p> <p>d Type of connection</p> <p>2 = radial M12 connector, 8-pin</p> <p>e Pulse rate</p> <p>1, 5, 10, 12, 36, 100, 200, 250, 256, 360, 400, 500, 512, 600, 800, 1000, 1024, 1200, 2000, 2048, 2500, 3600, 4096, 5000 (e.g. 100 pulses => 0100)</p> | <p><i>Optional on request</i></p> <ul style="list-style-type: none"> - other pulse rates - Ex 2/22 - seawater resistant (stainless steel V4A) <p><i>Stainless steel V4A as standard types (deliverable as from 1 unit)</i></p> <p>V4A 8.5026.18X2.XXXX-V4A</p> <p>1.4404</p> |
|---|--|--|

Incremental encoders

Standard stainless steel, optical	Sendix 5006 / 5026 (shaft / hollow shaft)	Push-pull / RS422
--	--	--------------------------

Mounting accessory for hollow shaft encoders		Dimensions in mm [inch]	Order no.
Isolation / adapter inserts for hollow shaft encoders 	Thermal and electrical isolation of the encoders (Temperature range -40 °C ... +115 °C [-40 °F ... +239 °F]) Isolation inserts prevent currents from passing through the encoder bearings. These currents can occur when using inverter controlled three-phase or AC vector motors and considerably shorten the service life of the encoder bearings. In addition the encoder is thermally isolated as the plastic does not transfer the heat to the encoder.	D1	Isolation insert
		6 mm [0.24"]	8.0010.4021.0000
		8 mm [0.32"]	8.0010.4020.0000
		10 mm [0.39"]	8.0010.4023.0000
		12 mm [0.47"]	8.0010.4025.0000
		1/4"	8.0010.4022.0000
3/8"	8.0010.4024.0000		
1/2"	8.0010.4026.0000		

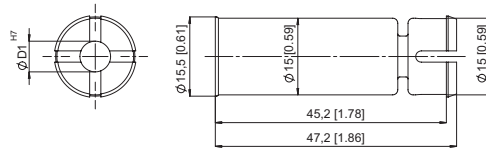

Tip:
By using these adapter inserts you can achieve six different hollow shaft diameters, all on the basis of the encoder 8.5026.X8X2.XXXX.

Cables and connectors		Order no.
Connectors	M12 female connector with coupling nut, 8-pin, A-coded, straight, stainless steel	8.0000.5136.0000.V4A

Further Kübler accessories can be found at: kuebler.com/accessories
 Further Kübler cables and connectors can be found at: kuebler.com/connection-technology

Technical data

Electrical characteristics				
Output circuit	RS422 (TTL compatible))		Push-pull	Push-pull (7272 compatible)
Supply voltage	5 V DC (±5 %)		10 ... 30 V DC	5 ... 30 V DC
Current consumption with inverted signal (no load)	typ. 40 mA max. 90 mA		typ. 50 mA max. 100 mA	typ. 50 mA max. 100 mA
Permissible load / channel	max. +/- 20 mA		max. +/- 20 mA	max. +/- 20 mA
Pulse frequency	max. 300 kHz		max. 300 kHz	max. 300 kHz
Signal level	HIGH	min. 2.5 V	min +V - 1.0 V	min. +V - 2.0 V
	LOW	max. 0.5 V	max. 0.5 V	max. 0.5 V
Rising edge time t_r	max. 200 ns		max. 1 µs	max. 1 µs
Falling edge time t_f	max. 200 ns		max. 1 µs	max. 1 µs
Short circuit proof outputs¹⁾	yes ²⁾		yes	yes
Reverse polarity protection of the supply voltage	no		yes	no

Mechanical characteristics	
Maximum speed³⁾	6000 min ⁻¹
Mass moment of inertia	approx. 1.8 x 10 ⁻⁶ kgm ²
Starting torque – at 20 °C [68 °F]	< 0.05 Nm
Weight	approx. 0.4 kg [14.11 oz]
Load capacity of shaft	radial 80 N axial 40 N
Protection acc. to EN 60529	IP66 / IP67
Working temperature	-40 °C ... +85 °C [-40 °F ... +185 °F]
Material	housing, flange, shaft stainless steel, 1.4305 (V2A) connector stainless steel
Shock resistance acc. to EN 60068-2-27	2500 m/s ² , 6 ms
Vibration resistance acc. to EN 60068-2-6	100 m/s ² , 10 ... 2000 Hz

Approvals	
UL compliant in accordance with	File no. E224618
CE compliant in accordance with	
EMC Directive	2014/30/EU
RoHS Directive	2011/65/EU
ATEX Directive	2014/34/EU (for Ex 2/22 variants)

1) If supply voltage correctly applied.
 2) Only one channel allowed to be shorted-out:
 at +V = 5 V DC, short-circuit to channel, 0 V, or +V is permitted.
 at +V = 5 ... 30 V DC, short-circuit to channel or 0 V is permitted.
 3) For continuous operation max. 3000 min⁻¹.

Incremental encoders

Standard stainless steel, optical	Sendix 5006 / 5026 (shaft / hollow shaft)	Push-pull / RS422
--	--	--------------------------

Terminal assignment

Output circuit	Type of connection	M12 connector, 8-pin									
2, 4, 5	5006: 4	Signal:	0 V	+V	A	\bar{A}	B	\bar{B}	0	$\bar{0}$	\pm
	5026: 2	Pin:	1	2	3	4	5	6	7	8	PH ¹⁾

Top view of mating side, male contact base

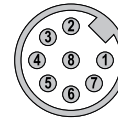

M12 connector, 8-pin

- +V: Supply voltage encoder +V DC
- 0 V: Supply voltage encoder ground GND (0 V)
- A, \bar{A} : Incremental output channel A
- B, \bar{B} : Incremental output channel B
- 0, $\bar{0}$: Reference signal
- PH \pm : Plug connector housing (shield)

Dimensions shaft version

Dimensions in mm [inch]

Synchro flange, \varnothing 58 [2.28] Flange type A

1 3 x M4, 6 [0.24] deep

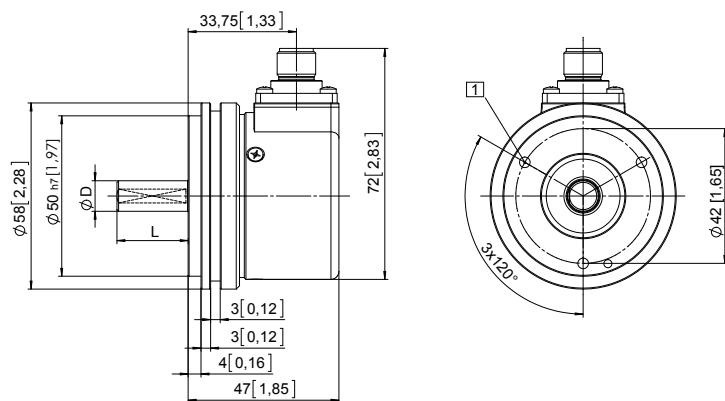

D	Fit	L
6 [0.24]	h7	10 [0.39]
10 [0.39]	f7	20 [0.79]
3/8"	h8	7/8"

Clamping flange, \varnothing 58 [2.28] Flange type 7

1 3 x M3, 5.5 [0.22] deep

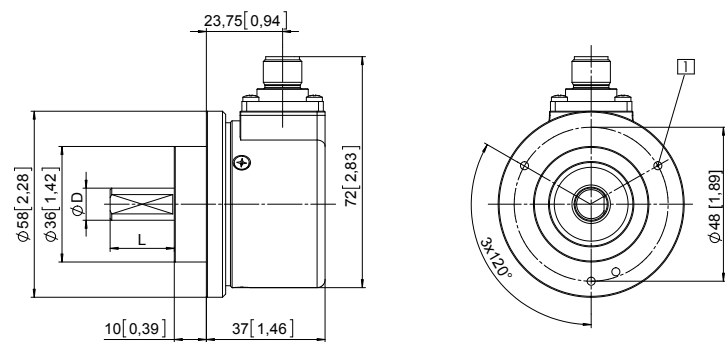

D	Fit	L
6 [0.24]	h7	10 [0.39]
10 [0.39]	f7	20 [0.79]
3/8"	h8	7/8"

Square flange, \square 63.5 [2.5] Flange type C

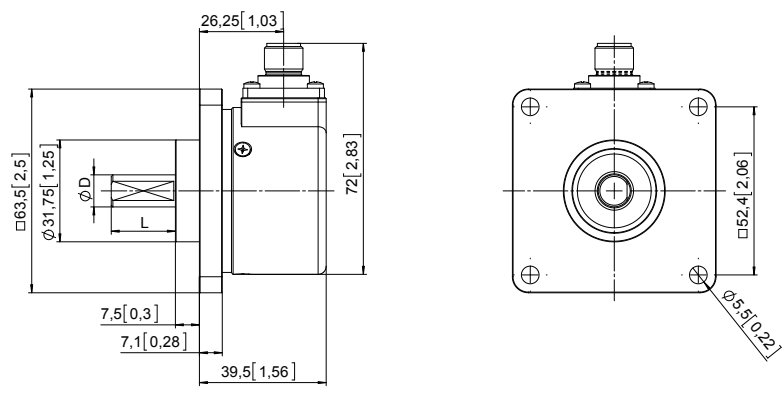

D	Fit	L
6 [0.24]	h7	10 [0.39]
10 [0.39]	f7	20 [0.79]
3/8"	h8	7/8"

1) PH = shield is attached to connector housing.

Incremental encoders

Standard stainless steel, optical

Sendix 5006 / 5026 (shaft / hollow shaft)

Push-pull / RS422

Dimensions hollow shaft version

Dimensions in mm [inch]

Flange with spring element, long Flange type 1

- 1 3 x M3, 6 [0.24] deep
- 2 Slot spring element, recommendation: torque pin DIN 7, \varnothing 4 [0.16]
- 3 Recommended torque for the clamping ring 0.6 Nm

D	Fit
10 [0.39]	H7
12 [0.47]	H7
15 [0.99]	H7
1/4"	H7
3/8"	H7
1/2"	H7

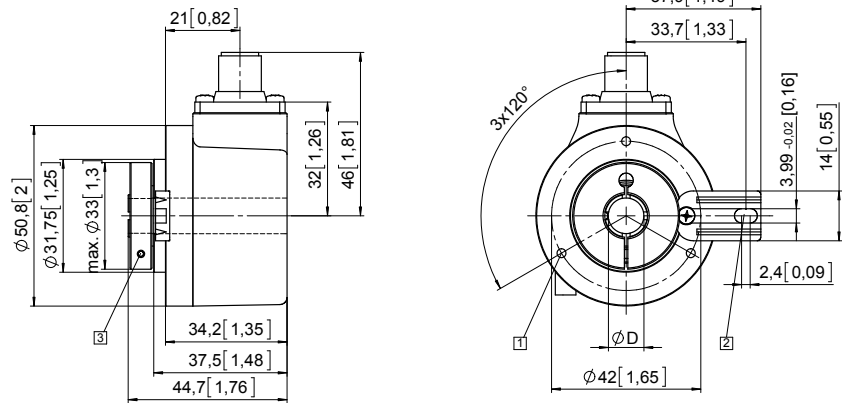

Flange with stator coupling, \varnothing 63 [2.48] Flange type C

- 1 Recommended torque for the clamping ring 0.6 Nm

D	Fit
10 [0.39]	H7
12 [0.47]	H7
15 [0.99]	H7
1/4"	H7
3/8"	H7
1/2"	H7

