

Displacement sensor amplifier unit

CDA series



Amplifier unit that can perform calculations and CC-Link communication

- | Up to two displacement sensors can be connected
- | Features a clear organic EL display
- | Can also display in Japanese



FASTUS is a product brand of Optex FA.

Related products	Ultra-high accuracy CDX ● P.438	Compact type CD22 ● P.464	CC-Link communication UC1 ● P.118

Selection table

Type	Supported displacement sensor	Supported communication unit	Master/slave unit	Model
Displacement sensor amplifier unit	<ul style="list-style-type: none"> •CD22 series (RS-485 type) •CDX series ● P.438, P.464	CC-Link communication unit UC1-CL11 (only for CD22 series) ● P.118	Master unit	CDA-M
			Slave unit	CDA-S

Options/Accessories

Displacement sensor/amplifier connection cable



DSL-1204-G02M
Cable length: 2 m
Robot cable specification

Extension cable

DSL-0804-G02M
Cable length: 2 m
Cable length between sensor and amplifier can be extended to 4 m by connecting to DSL-1204-G02M.
Robot cable specification

DSL-0804-G05M
Cable length: 5 m
Cable length between sensor and amplifier can be extended to 7 m by connecting to DSL-1204-G02M.
Robot cable specification

Features

Calculation function

Up to two can be connected to the CDA series. High-speed calculation of thickness and height differences can be performed with one amplifier unit.

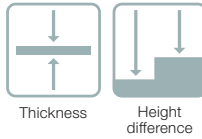

CC-Link connection

By connecting to UC1 series communication unit, CD22 series can be connected to CC-Link. Monitoring of measurement values and remote monitoring of sensors can be performed easily.

Sensors can be operated through CC-Link communication using Mitsubishi Electric's GX Works2 which supports Mitsubishi iQ Sensor Solution (iQSS).

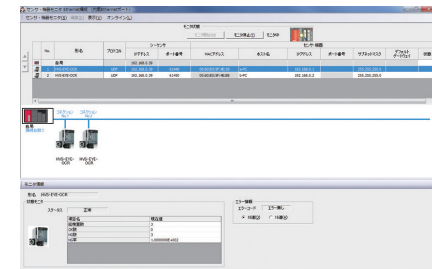
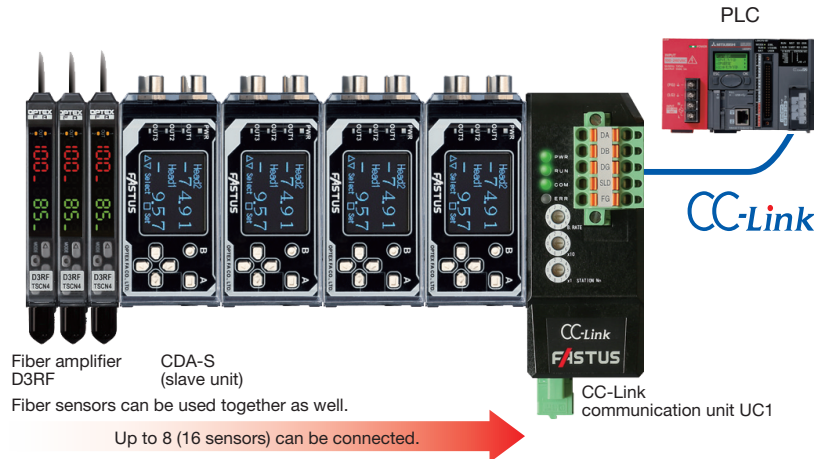

- Model information and no. of connected units are detected automatically
- Reading, writing, monitoring and backing up of set sensor values is possible

System configuration

CDA only

When using CDA as stand-alone



When CDA is linked

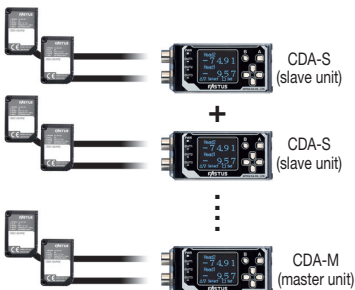

CDA+UC1 (Not for CDX)

When using CDA as stand-alone



When CDA is linked

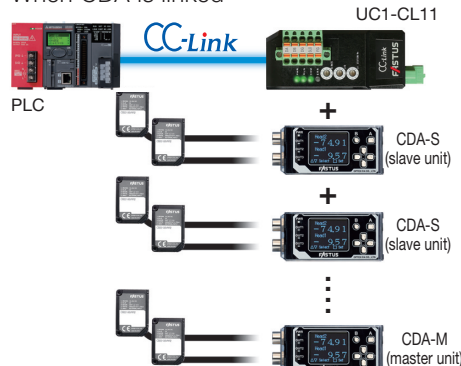

CDA + UC1 + D3RF (Not for CDX)

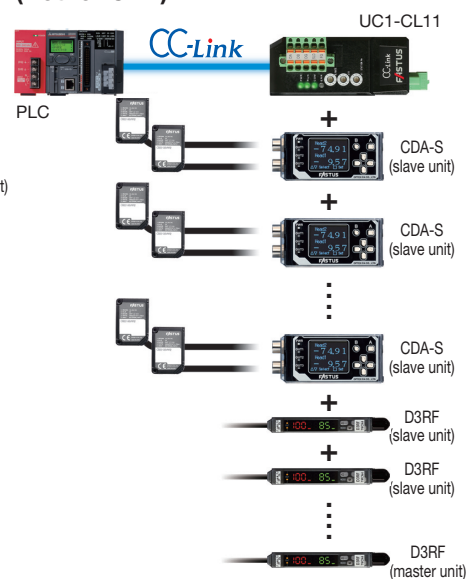

Photoelectric Sensors

Specialized Photoelectric Sensors

Laser Displacement Sensors

Control Unit

CDX

CDA

LS

CD22

CD33

CD4

CD5

UQ1-01

UQ1-02

Specifications

Model		Master unit	Slave unit
		CDA-M	CDA-S
Displacement sensor	No. of connectable units	Max. 2 units of CD22 or CDX series (Connectable model of CD22 series: CD22-□□-485M12)	
	Connection type	Amplifier side: M8, 4-pin connector / Sensor side: M12, 4-pin connector	
No. of connectable units (including master unit)		Max. 8 units	
Rating	Supply voltage	12 to 24 VDC $\pm 10\%$, including 10% ripple (p-p)	Supplied from master unit or UC1 series*
	Current consumption	100 mA or less (at 12 VDC)	
Display	Dot matrix display	Organic EL panel 128 \times 96 pixels	
	Indicators	Power indicator: Red/Green, Output indicator 1 to 3: Orange	
Analog current output		4 to 20 mA/F.S. Load impedance 300 Ω or less	
Control output		NPN/PNP open collector (selectable by setting) 3 output max. 100 mA / 30 VDC, Residual voltage: 1.8 V or less	
External input		2 inputs	
Connection type		Cable type: Cable: 2 m ($\phi 5.8$)	
Environmental resistance	Ambient temperature/humidity	-20 to +50°C / 35 to 85% RH (no freezing or condensation)	
	Storage temperature/humidity	-20 to +60°C / 35 to 85% RH (no freezing or condensation)	
	Vibration resistance	10 to 55 Hz; double amplitude 1.5 mm; 2 hours in each of the X, Y, and Z directions	
	Shock resistance	Approximately 50 G (500 m/s ²), 3 times in each of the X, Y, and Z directions	
	Protection circuit	Reverse connection protection	
	Degree of protection	IEC standard, IP50	
Material		Polycarbonate	
Weight		170 g	

*Supply 12 to 24 VDC to power wires (brown/blue) to be used for the supply voltage of the CD22 series.

I/O circuit diagram

■ With the NPN setting

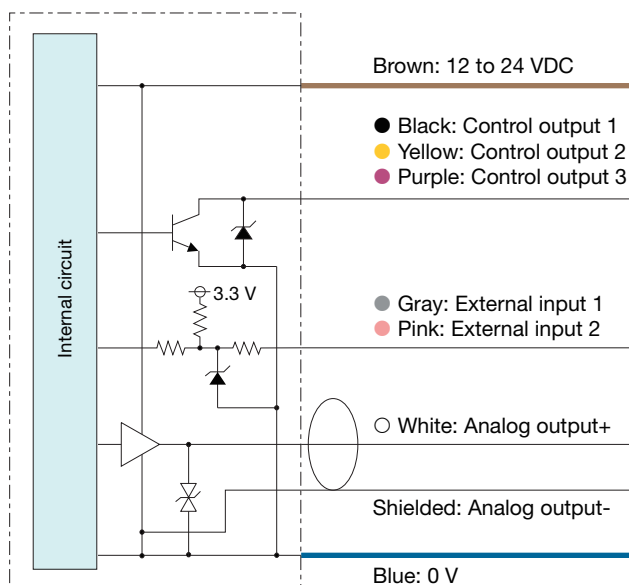

■ With the PNP setting

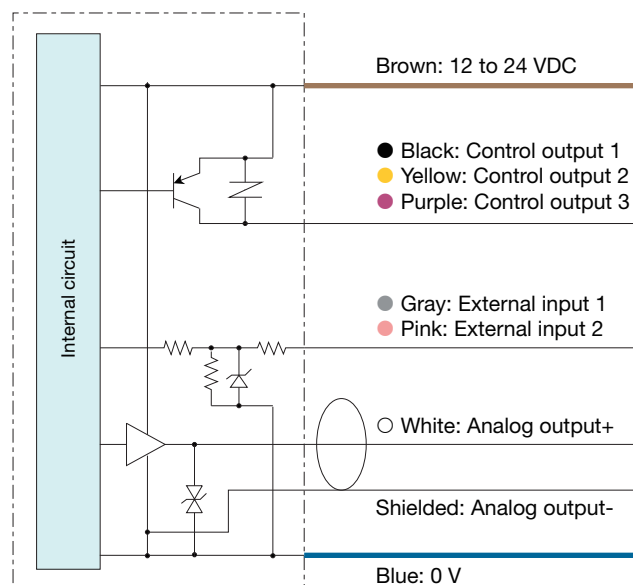

Photoelectric Sensors

Specialized Photoelectric Sensors

Laser Displacement Sensors

Control Unit

CDX

CDA

LS

CD22

CD33

CD4

CD5

UQ1-01

UQ1-02

Dimensions

Amplifier unit

(Unit: mm)

■ CDA-M / CDA-S

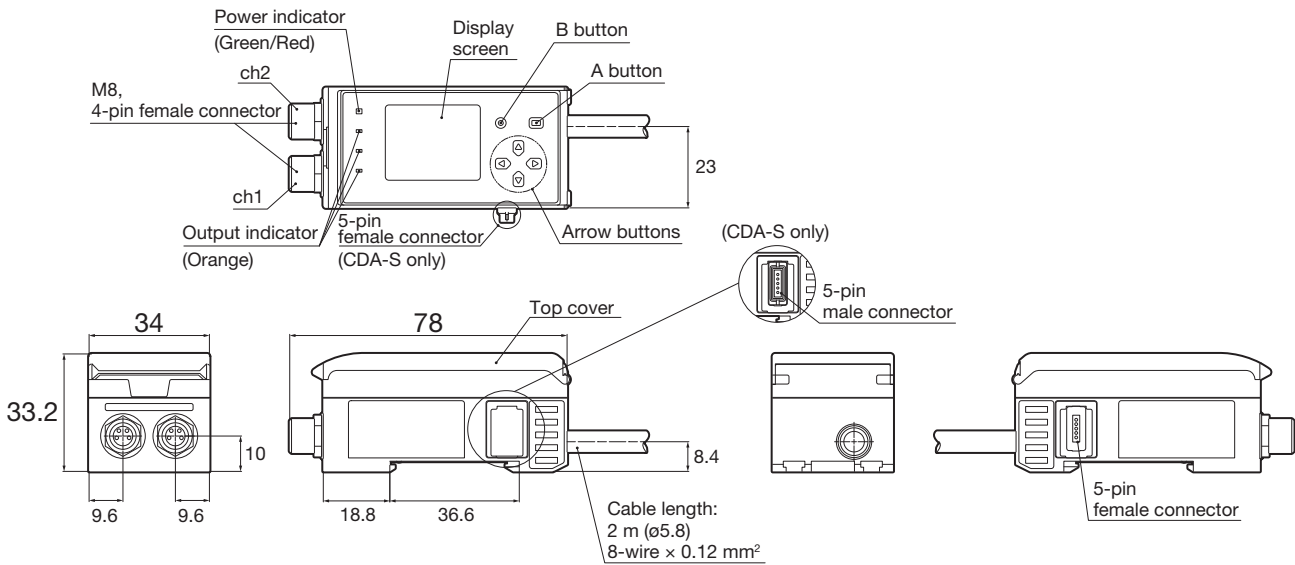

Displacement sensor/amplifier connection cable

■ DSL-1204-G02M

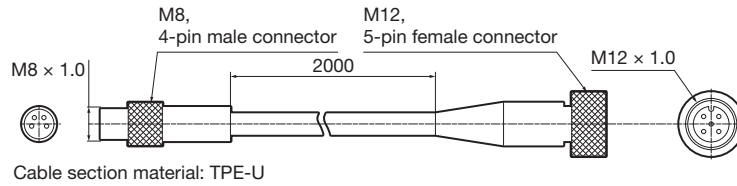

Extension cable

■ DSL-0804-G02M / DSL-0804-G05M

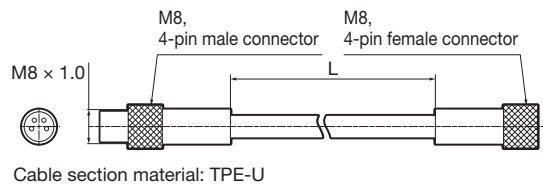

DSL-0804-G02M: L = 2000,
DSL-0804-G05M: L = 5000

Photoelectric Sensors

Specialized Photoelectric Sensors

Laser Displacement Sensors

Control Unit

CDX

CDA

LS

CD22

CD33

CD4

CD5

UQ1-01

UQ1-02