

*FASTUS is a product brand of OPTEX FA.

[Sold separately:
CDA-DM2 amplifier unit]

Edge Position Measurement for Any Workpiece



Suitable for
edge measurement
and width/gap
measurement

Light axis alignment
function for
easy installation

Easily readable
amplifier unit
Sold separately: CDA-DM2

Edge Measurement

The TD1 Series is ideal for equipment where edge control is required, such as for measurement of the end surfaces of components or sheet materials.

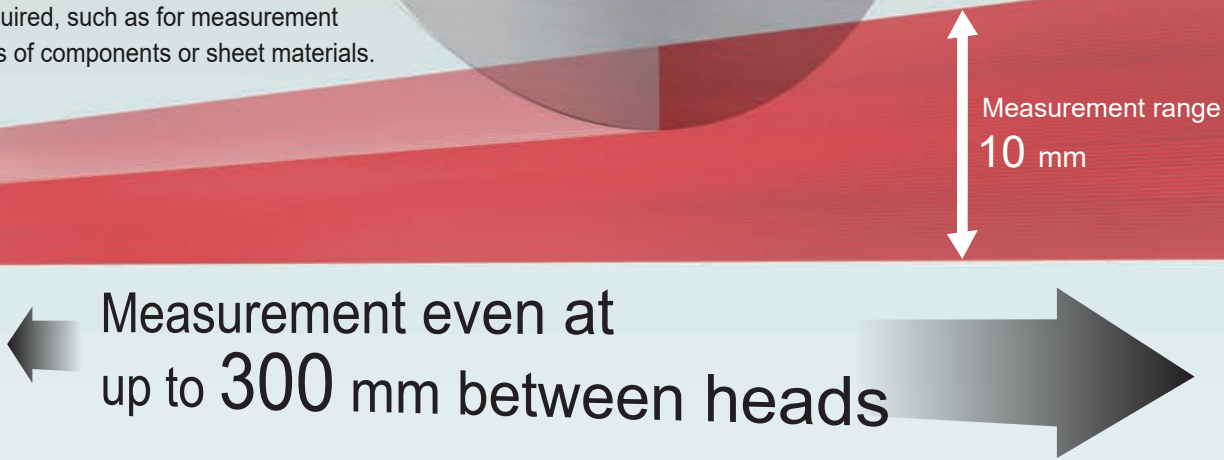

Through-beam edge sensor TD1 Series devices use a CMOS sensor as the light receiving element, allowing for highly accurate edge position measurement of end surfaces.

Repeatability
 $\pm 5 \mu\text{m}$

Linearity
 $\pm 0.4\%$
of F.S.

Easy Light Axis Alignment

In Direction Checking mode, the indicator will flash when the light axis is misaligned, notifying that the alignment should be checked.

This makes it easier to check the light axis when installing sensors or during periodic maintenance.

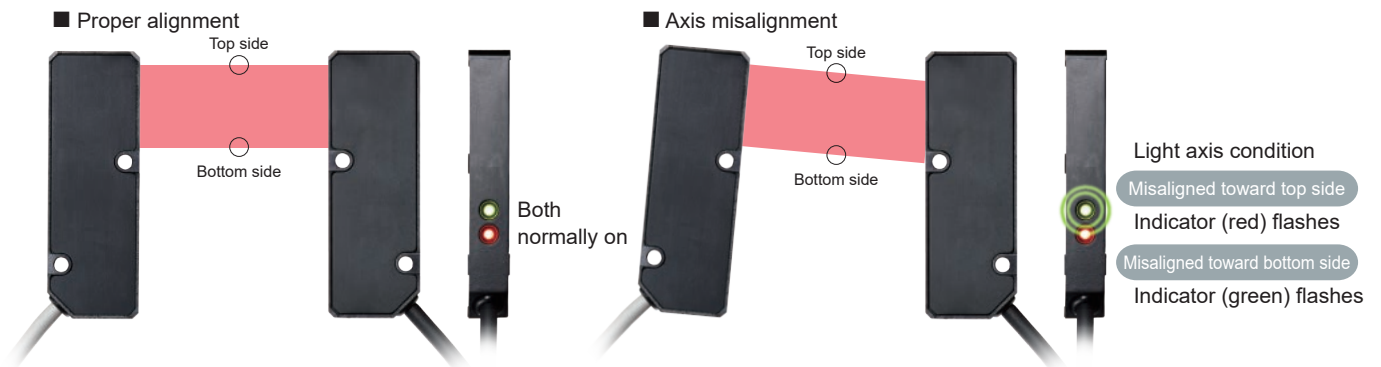

Compact Design

The compact size of the sensor head allows for easy installation even for devices with limited space. This makes it possible to keep equipment as small as possible.

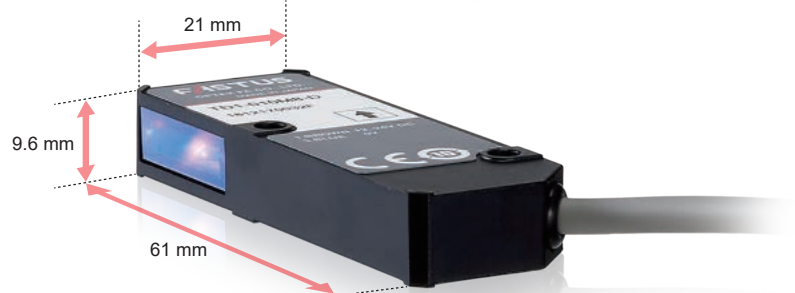

Width/Gap Measurement

The measurement method used in a TD1 Series product can be changed to suit the inspection application, such as when measuring the width of small electronic components or the gaps between rollers.

■ Width measurement

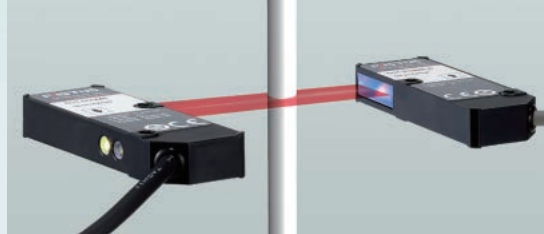

■ Gap measurement



Displacement sensor amplifier unit

CDA Series

CDA-DM2

Features an organic EL display that can display clearly in both Japanese and English.

Calculations can be performed with up to two TD1 Series units.

[Actual size]

Easily readable display

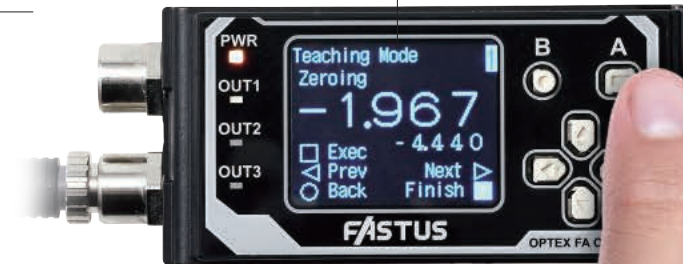

One-touch detection target position teaching

Simple Teaching Mode

When teaching, the edge center position can be set as desired within the measurement range. Simply place the measurement target and press the button.

Calculation Function

Connecting two TD1 Series units enables measurement of workpieces with outer diameters of 10 mm or more.

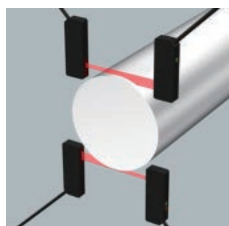

Cylindrical workpiece outer diameter measurement



System Configuration Diagram

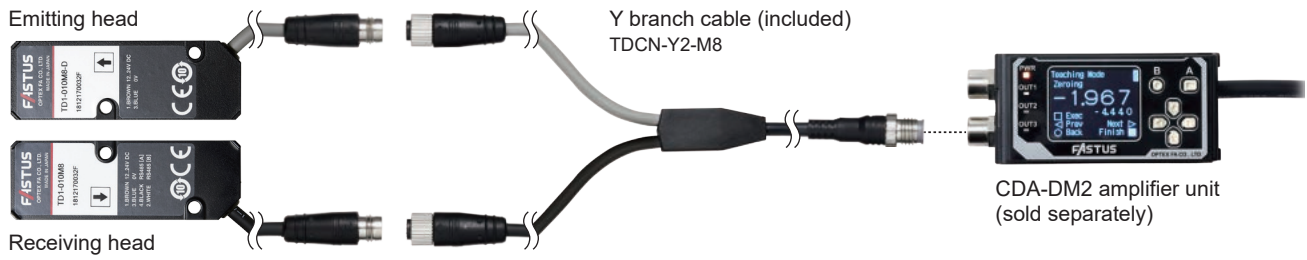

● Up to two units per amplifier

Options/Accessories

■ Amplifier unit

- CDA-DM2 Dual analog output type

NEW



■ Sensor-to-amplifier extension cable

- DSL-0804-G02M Cable length: 2 m, robot cable specification
- DSL-0804-G05M Cable length: 5 m, robot cable specification

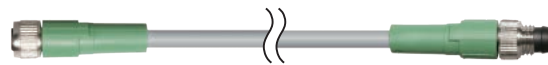

● Ensure that the cable length when using a CDA Series amplifier unit is within 10 m.

Specifications

■ Sensor head

Model		TD1-010M8
Measurement range		Edge: ± 5 mm, width: 10 mm
Distance between heads		Max. 300 mm
Light source	Medium (Wavelength)	Red semiconductor laser (Wavelength: 660 nm)
	Maximum output	390 μ W
Laser class		Class 1 (IEC/JIS) / Class I (FDA)*1
Spot size		3 \times 14 mm
Linearity		With a distance between heads of 100 mm: $\pm 0.4\%$ of F.S. (± 40 μ m)
Repeatability*2		± 4 μ m
Sampling period		500 μ s
Temperature drift		$\pm 0.02\%$ of F.S./ $^{\circ}$ C
Indicators		[Emitting head] Power indicator: Green [Receiving head] Power indicator: Green, Alarm indicator: Red
Serial interface		RS-485
Supply voltage		12 to 24 VDC $\pm 10\%$
Current consumption		Emitting head: 20 mA or less (at 12 VDC) Receiving head: 80 mA or less (at 12 VDC)
Connection type		Pig tail type: Cable with M8, 4-pin connector, 300 mm length
Environmental resistance	Ambient temperature/humidity	-10 to $+50^{\circ}$ C / 35 to 85% RH (no freezing or condensation)
	Storage temperature/humidity	-20 to $+60^{\circ}$ C / 35 to 85% RH (no freezing or condensation)
	Ambient illuminance	Sunlight: 10,000 lx or less, Incandescent lamp: 3,000 lx or less
	Vibration resistance	10 to 55 Hz; double amplitude 1.5 mm; 2 hours in each of the X, Y, and Z directions
	Shock resistance	Approx. 50 G (500 m/s ²), 3 times in each of the X, Y, and Z directions
	Protection circuit	Reverse connection protection
	Degree of protection	IP50
Applicable regulations	EMC	EMC directive (2014/30/EU)
	Environment	RoHS directive (2011/65/EU), China RoHS (Directive No. 32)
	Safety	FDA regulations (21 CFR 1040.10 and 1040.11)*3
Applicable standards		EN60947-5-2
NRTL Certification		Recognized Components Proximity Switch Certified for US and Canada.
Material		Housing: Aluminum die cast, Emitting/receiving part: Glass
Weight		Emitting head, receiving head: 30 g each (including 300 mm connector cable)

■ Amplifier unit

Type		Dual analog output
Model		CDA-DM2
Sensor head	No. of connectable units	Max. 2 units
	Connection type	Amplifier side: M8, 4-pin connector
Display	Dot matrix display	Organic EL panel, 128 \times 96 pixels
	Indicators	Power indicator: Red/Green, Output indicator: Orange
Supply voltage		12 to 24 VDC $\pm 10\%$, including 10% ripple (p-p)
Current consumption		120 mA or less (at 12 V)*1
Analog output	No. of outputs	2 outputs
	Type	4 to 20 mA/F.S. Load impedance 300 Ω or less, 0 to 10 V output impedance 100 Ω (switchable)
Control output	No. of outputs	2 outputs
	Type	NPN/PNP open collector (switchable), Max. 100 mA / 30 VDC, Residual voltage: 1.8 V or less
External input		1 input
Connection type		Cable type: Cable: 2 m ($\phi 5.8$)
Environmental resistance	Ambient temperature/humidity	-20 to $+50^{\circ}$ C / 35 to 85% RH (no freezing or condensation)
	Storage temperature/humidity	-20 to $+60^{\circ}$ C / 35 to 85% RH (no freezing or condensation)
	Vibration resistance	10 to 55 Hz; double amplitude 1.5 mm; 2 hours in each of the X, Y, and Z directions
	Shock resistance	Approx. 50 G (500 m/s ²), 3 times in each of the X, Y, and Z directions
	Protection circuit	Reverse connection protection, overcurrent protection
	Degree of protection	IP50
Applicable regulations	EMC	EMC Directive (2014/30/EU)
	Environment	RoHS Directive (2011/65/EU), China RoHS (Directive No. 32)
Applicable standards		EN 60947-5-2
NRTL Certification		Recognized Components Proximity Switch Certified for US and Canada.
Material		Housing: Polycarbonate
Weight		170 g

*1 Does not include current supplied to any connected sensor head or expansion unit.

*1 In accordance with the FDA provisions of Laser Notice No. 50, the laser is classified as Class 1 per the IEC 60825-1:2007 standard.

*2 With an averaging count of one.

*3 Excluding differences in Laser Notice No. 56.

/ Applications

Sheet material winding control

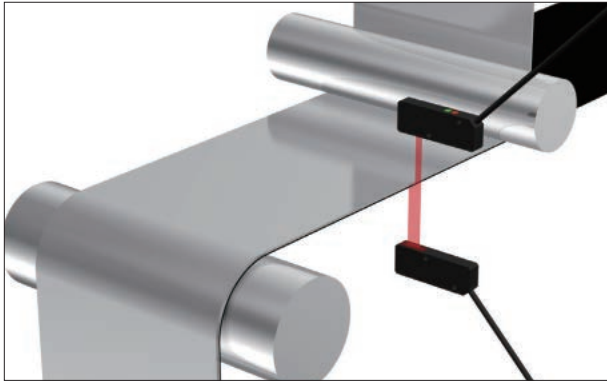

Sheet material meander control/edge measurement

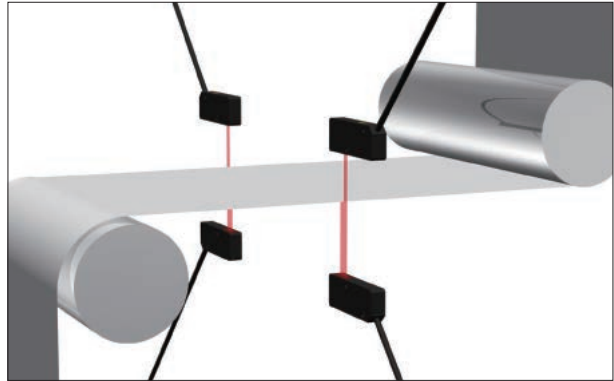

Cylindrical workpiece outer diameter measurement

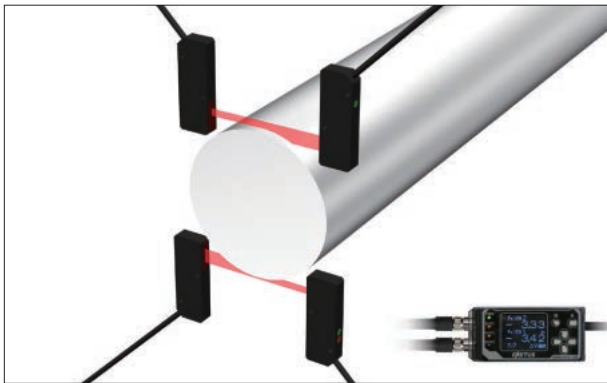

Wafer alignment

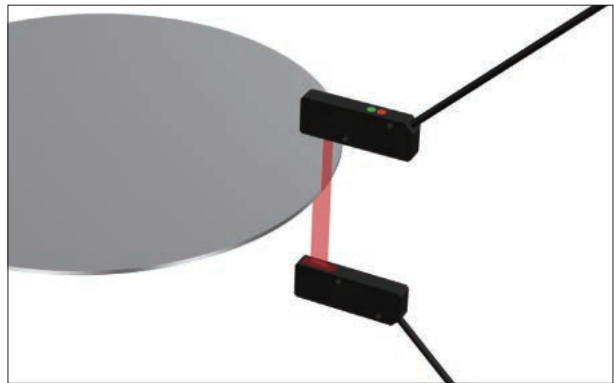

Electronic component orientation identification

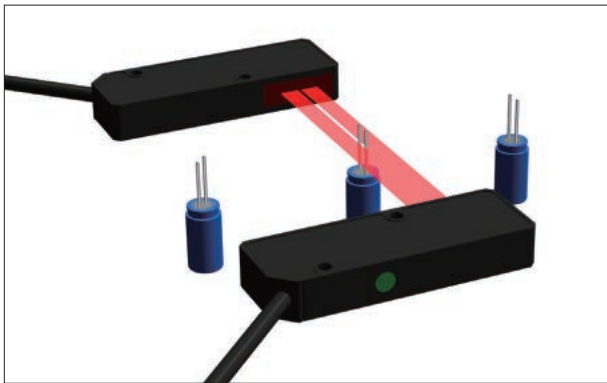

Bottle cap float detection

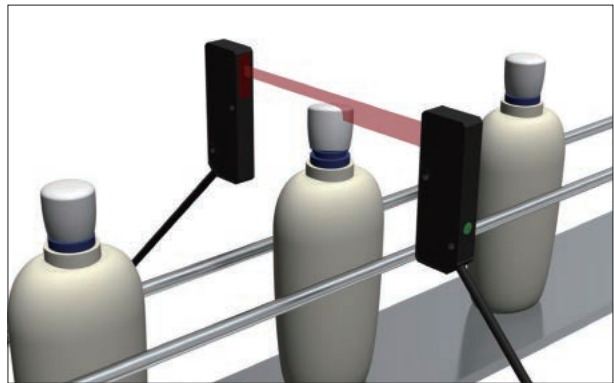

Rubber sheet defect inspection

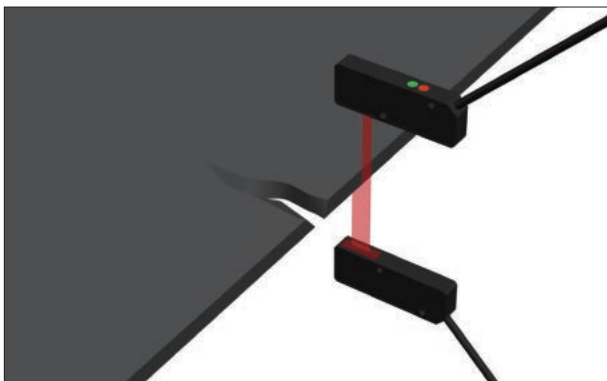

Roller gap measurement

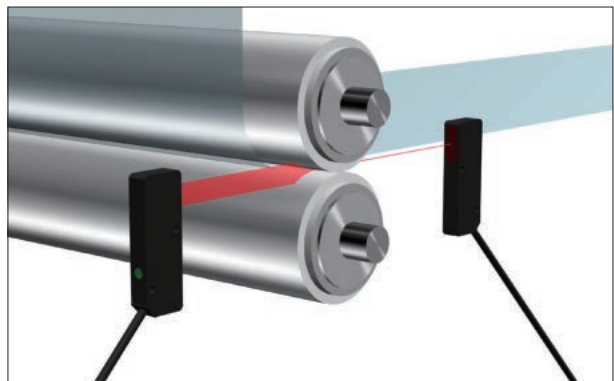

Dimensions (Unit: mm)

TD1 Series

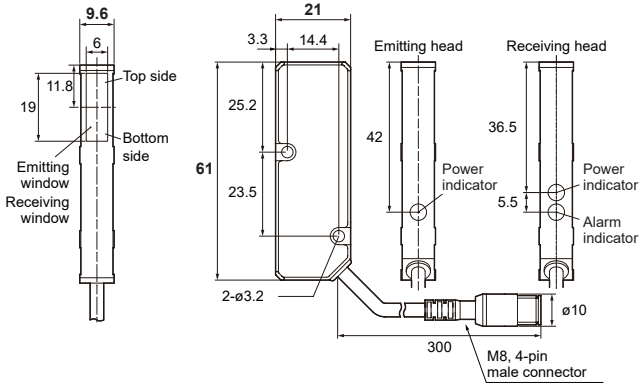

TDCN-Y2-M8 Y branch cable

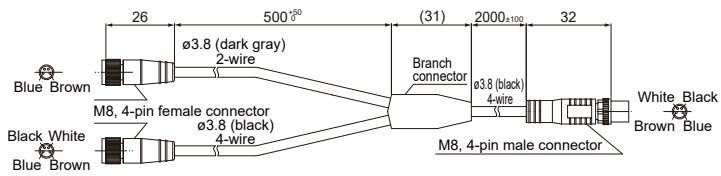

CDA-DM2 amplifier unit

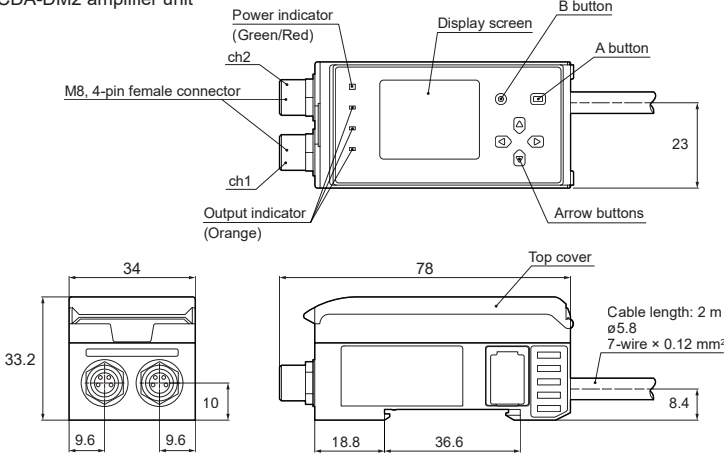

DSL-0804-G02M / DSL-0804-G05M sensor-to-amplifier extension cable

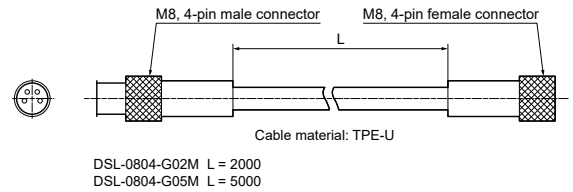

I/O Circuit Diagram (CDA-DM2 amplifier unit)

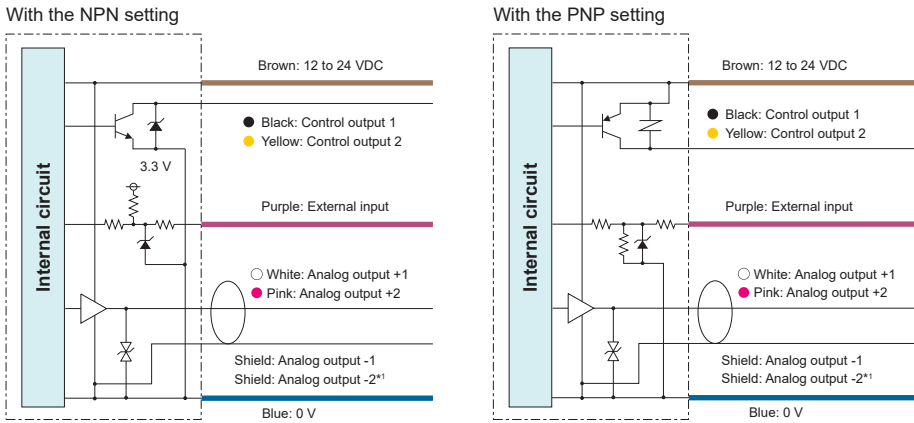

*1 Use shielded cables for analog output (+) and analog output (-), and wire as a pair up to the analog input device.

Attention: Not to be Used for Personnel Protection.

Never use these products as sensing devices for personnel protection. Doing so could lead to serious injury or death. These sensors do not include the self-checking redundant circuitry necessary to allow their use in personnel safety applications. A sensor failure or malfunction can cause either an energized or de-energized sensor output condition. Please consult our distributors about safety products which meet OSHA, ANSI and IEC standards for personnel protection.

- Specifications are subject to change without prior notice.
- Specifications and technical information not mentioned here are written in Instruction Manual. Or visit our website for details.
- All the warnings and cautions to know prior to use are given in Instruction Manual.



OPTEX FA CO., LTD.

91 Chudoji-Awata-cho Shimogyo-ku Kyoto 600-8815 JAPAN
 TEL. +81-75-325-1314 FAX. +81-75-325-2931
<https://www.optex-fa.com>